

KRIBIOLISA® Semaglutide (OZEMPIC™) ELISA





REF : KBI5030

Ver 6.7

RUO

This Kit has been Calibrated against commercially sourced referenced therapeutic product, OZEMPIC™ Injection.

Immunoassay for Quantitative Estimation of Semaglutide in biological solutions and human serum and plasma

RUO	For Research Use Only	REF	Catalog Number
	Store At	LOT	Batch Code
	Manufactured By		Biological Risk
	Expiry Date		Consult Operating Instructions

For Research Use Only. Purchase does not include or carry the right to resell or transfer this product either as a stand-alone product or as a component of another product. Any use of this product other than the permitted use without the express written authorization of Krishgen Biosystems Private Limited is strictly prohibited.

REF KBI5030

 **96 tests**

Krishgen Biosystems Private Limited

For US/Europe Customers: toll free +1(888)-970-0827 | tel +1(562)-568-5005

For Asia/India Customers: tel +91(22)-49198700

Email: sales1@krishgen.com | <http://www.krishgen.biz> / www.krishgenbio.com

Introduction:

Semaglutide (trade name **OZEMPIC**) is a pharmaceutical drug in development by a Danish company Novo Nordisk for the treatment of type 2 diabetes. It is marketed by the name OZEMPIC. As a glucagon-like peptide-1 receptor agonist, it lowers the blood sugar level by increasing the production of insulin. It was discovered in 2012, by a team of researchers at Novo Nordisk as a longer-acting alternative to liraglutide. Clinical trials were started in 2015, and phase 3 was completed in 2016. FDA approval was applied in December 2016, and in October 2017 FDA Advisory Committee voted 16-0 in favor. It can be used as both injection-type or oral-type drug.

Chemical Structure Depiction:

Trade Names:

OZEMPIC, Rybelsus, Wegovy

Generic Name:

Semaglutide

PubChem CID:

56843331

DrugBank Accession Number:

DB13928

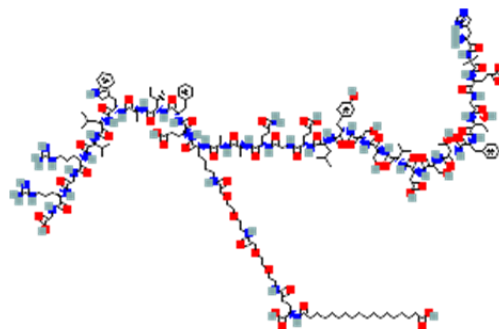

Intended Use:

The KRIBIOLISA® Semaglutide (OZEMPIC™) ELISA kit is used for estimation of Semaglutide in biological solutions and human serum.

Principle:

The Semaglutide ELISA is a competitive immunoassay for the determination of Semaglutide. The anti-GLP-1 antibodies are coated on 96 well plate. A constant concentration of Biotinylated GLP-1 and varying concentration of unlabeled Semaglutide or sample compete for binding to anti-GLP-1 antibodies. Captured Biotinylated GLP-1 antibodies are subsequently bound by Streptavidin:HRP which produces a soluble colored product after addition of 3, 3', 5, 5' Tetra Methyl Benzidine substrate solution (TMB) substrate. The enzyme reaction is stopped by dispensing of stop solution into the wells. The optical density (OD) of the solution at 450 nm is inversely proportional to the amount of bound Semaglutide molecule present in standards or samples.

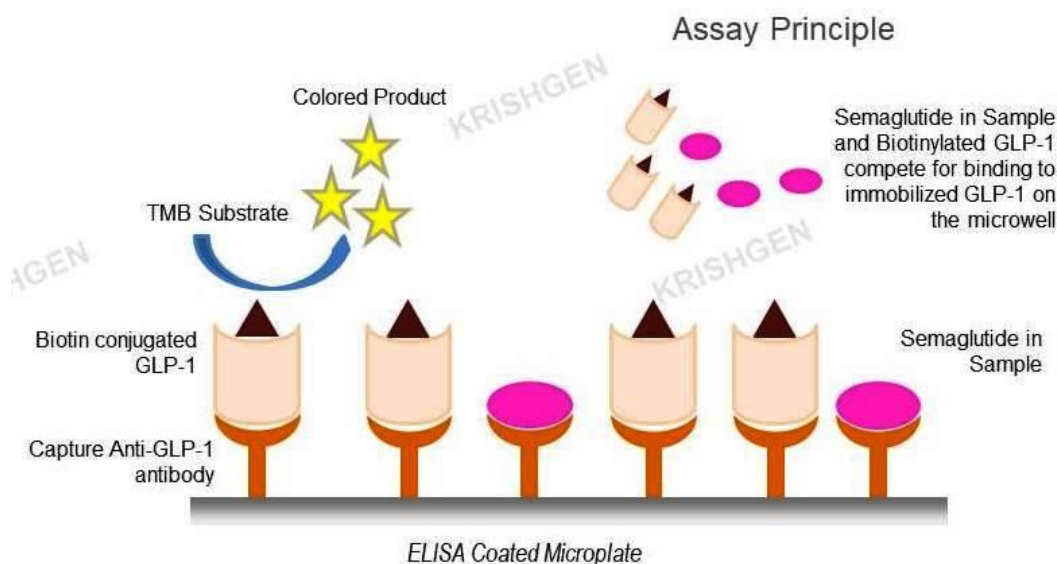

Materials Provided:

Part	Description	Qty
Anti-GLP-1 Coated Microtiter Plate	96 well polystyrene microplate (12 strips of 8 wells) coated with Anti-GLP-1 monoclonal antibody	1 x 96 wells
Semaglutide Standard	Recombinant Semaglutide standard and preservative sodium azide <0.1% (lyophilized; 4000 ng/ml)	2 vials
GLP-1 Biotin Concentrated	Concentrated Biotinylated GLP-1 (10 ul)	1 vial
Streptavidin:HRP Conjugate Concentrated	Concentrated Streptavidin HRP (10 ul)	1 vial
(1X) Standard Diluent	Buffered protein base with protein stabilizer and 1:100 human serum and preservative sodium azide <0.1%	10 ml
(1X) Sample Diluent	Buffered protein base with BSA and preservative sodium azide < 0.1%	50 ml
Streptavidin:HRP Diluent	Buffer with protein stabilizer and preservatives 0.02% methylisothiazolinone and 0.02% bromonitrodioxane	12 ml
Biotin Diluent	Buffer with protein stabilizer and preservatives 0.02% methylisothiazolinone and 0.02% bromonitrodioxane	10 ml
(20X) Wash Buffer	20-fold concentrated solution of buffered surfactant with preservative thiomersal <0.01%. May turn yellow over time	25 ml
TMB Substrate	Stabilized Chromogen	12 ml
Stop Solution	0.73M Phosphoric Acid	12 ml
Instruction Manual		1 no

Materials to be provided by the End-User:

1. Microplate Reader able to measure absorbance at 450 nm.
2. Adjustable pipettes to measure volumes ranging from 50 ul to 1000 ul.
3. Deionized (DI) water.
4. Wash bottle or automated microplate washer.
5. Graph paper or software for data analysis.
6. Tubes to prepare standard/sample dilutions.
7. Timer.
8. Absorbent paper.
9. Incubator.

Storage Information:

1. It is advisable to aliquot and store the GLP-1 Biotin concentrated at -20°C upon receipt. Rest of the kit components should be stored at 2-8°C. Immediately discard any excess Working GLP1-Biotin solution after running your assay.
2. All the reagents and wash solutions should be used within 12 months from manufacturing date.
3. Before using, bring all components to room temperature (18-25°C). Upon assay completion ensure all components of the kit are returned to appropriate storage conditions.
4. The Substrate is light-sensitive and should be protected from direct sunlight or UV sources.

Health Hazard Warnings:

1. Reagents that contain preservatives may be harmful if ingested, inhaled or absorbed through the skin. Refer to the MSDS online for details.

Specimen Collection and Handling:

Blood is taken by venipuncture. Serum is separated after clotting by centrifugation. Plasma can be used too. Lipaemic, hemolytic or contaminated samples should not be run. Repeated freezing and thawing should be avoided. If samples are to be used for several assays, initially aliquot samples and keep at -20°C.

For Serum & Plasma - Samples have to be **diluted 1:100 (v/v)**, e.g. **1 ul sample + 99 ul (1X) Sample Diluent** prior to assay. The samples may be kept at 2-8°C for up to three days. Long-term storage requires -20°C.

Reagent Preparation (all reagents should be diluted immediately prior to use):

1. Bring all kit components and samples to room temperature (18-25°C) before use. If the kit will not be used up in one time, please only take out strips and reagents for present experiment, and leave the remaining strips and reagents in required condition.
2. To make **Wash Buffer (1X)**; dilute 25 ml of 20X Wash Buffer in 475 ml of DI water.
3. **Standard:** Reconstitute the lyophilized standard in 1 ml of Standard diluent (1X) to get a concentration of 4000 ng/ml. Keep the standard for 15 minutes. 4000 ng/ml is the top standard. Prepare the remaining standards as per the below table. Standard Diluent (1X) serves as the zero standard (0 ng/ml).

Standard Concentration	Standard No	Dilution Particulars
4000 ng/ml	Reconstituted standard	Lyophilized Standard provided in the Kit + 1 ml of Standard Diluent (1X)
3000 ng/ml	Standard No. 6	750 ul of Reconstituted standard + 250 ul of Standard Diluent (1X)
2000 ng/ml	Standard No. 5	666.6 ul of Standard No. 6 + 333.4 ul Standard Diluent (1X)
1000 ng/ml	Standard No. 4	500 ul of Standard No. 5 + 500 ul Standard Diluent (1X)
500 ng/ml	Standard No. 3	500 ul of Standard No. 4 + 500 ul Standard Diluent (1X)
100 ng/ml	Standard No. 2	200 ul of Standard No. 3 + 800 ul Standard Diluent (1X)
50 ng/ml	Standard No.1	500 ul of Standard No. 2 + 500 ul Standard Diluent (1X)
0 ng/ml	Standard No. 0	Only Standard Diluent (1X)

4. **Working Biotinylated GLP-1:** Refer to the Reagent Preparation sheet attached with the IFU and COA (enclosed in the kit).
5. **Working Streptavidin:HRP Conjugate Solution:** Refer to the Reagent Preparation sheet attached with the IFU and COA (enclosed in the kit).

Procedural Notes:

1. In order to achieve good assay reproducibility and sensitivity, proper washing of the plates to remove excess un-reacted reagents is essential.
2. Avoid assay of Samples containing Sodium Azide (NaN₃), as it could destroy the HRP activity resulting in under-estimation of the amount of Semaglutide.
3. It is recommended that all Standards and Samples be assayed in duplicates.
4. Maintain a repetitive timing sequence from well to well for all the steps to ensure that the incubation timings are same for each well.
5. If the Substrate has a distinct blue color prior to use it may have been contaminated and use of such substrate can lead to low / incorrect results.
6. The plates should be read within 30 minutes after adding the Stop Solution.
7. It is advisable to make a work list in order to identify the location of Standards and Samples.

Assay Procedure:

1. It is strongly recommended that all Standards and Samples be run in duplicates or triplicates. A standard curve is required for each assay. All steps must be performed at 37°C.
2. Pipette **100 ul** of prepared **Standards** or diluted **Samples** into the respective wells.
3. Cover the plate and incubate for 90 minutes at 37°C.
4. Pipette **50 ul** of **Working Biotinylated GLP-1** into each well.
5. Cover the plate and incubate for 90 minutes at 37°C.

6. Aspirate and wash plate 4 times with **Wash Buffer (1X)** and blot residual buffer by firmly tapping plate upside down on absorbent paper. Wipe of any liquid from the bottom outside of the microtiter wells as any residue can interfere in the reading step.
7. Add **100 ul** of **Working Streptavidin:HRP Conjugate Solution** (freshly prepared using the 2-step method) in each well.
8. Incubate the microplate for 60 minutes at 37°C.
9. Aspirate and wash plate 4 times with **Wash Buffer (1X)** as mentioned in step 6.
10. Add **100 ul** of **TMB Substrate** in each well.
11. Incubate the plate at 37°C for 30 minutes in dark. DO NOT SHAKE or else it may result in higher backgrounds and worse precision. Positive wells should turn bluish in color.
12. Pipette out **100 ul** of **Stop Solution**. Wells should turn from blue to yellow in color.
13. Read the absorbance at 450 nm with a microplate within 10-15 minutes after addition of Stop solution.

Calculation of Results:

Determine the Mean Absorbance for each set of duplicate Standards and Samples. Using Graph paper, plot the average value (absorbance 450 nm) of each standard on the Y-axis versus the corresponding concentration of the standards on the X-axis. Draw the best fit curve through the standard points. To determine the unknown Semaglutide concentrations, find the unknown's Mean Absorbance value on the Y-axis and draw a horizontal line to the standard curve. At the point of intersection, draw a vertical line to the X-axis and read the Semaglutide Concentration. If samples were diluted, multiply by the appropriate dilution factor.

Software which is able to generate a linear regression like cubic spline or 4PL (2nd order) is best recommended for automated results.

Note:

It is recommended to repeat the assay at a different dilution factor in the following cases:

- If the sample absorbance value is below the first standard.
- If the absorbance value is equivalent or higher than the 4000 ng/ml standard.

Typical Data (representative only)

Standards (ng/ml)	Mean Abs	Interpolated Concentration	% Interpolated Concentration against Actual Concentration
0	2.823	--	--
50	2.211	36.7	73.3
100	1.922	147.8	147.8
500	1.694	334.3	66.9
1000	1.121	1489.6	149.0
2000	1.103	1548.0	77.4
3000	0.729	3185.0	106.2
4000	0.586	4061.9	101.5

Typical Graph (representative only)

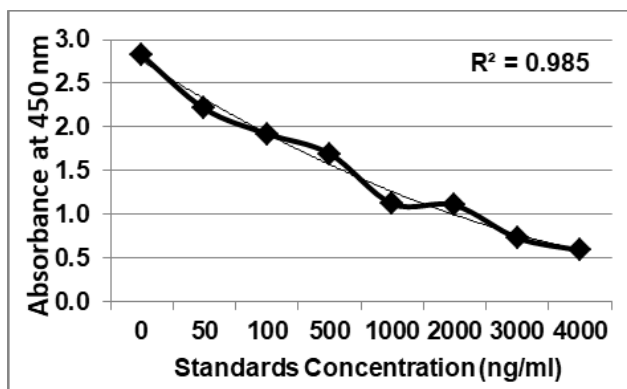

Quality Control:

It is recommended that for each laboratory assay appropriate quality control samples in each run to be used to ensure that all reagents and procedures are correct.

Performance Characteristics of the Kit:

This kit has been validated as per EMA/FDA guidelines in line with ICH Code for Harmonization of Biological Assays.

Sensitivity:

Limit Of Detection: It is defined as the lowest detectable concentration corresponding to a signal of Mean of '0' standard plus 2*SD.

10 replicates of '0' standards were evaluated and the LOD was found to be less than 50 ng/ml.

Specificity:

The capture monoclonal GLP-1 antibody used in the kit is reacts with the mid-molecular epitope of GLP-1 {Glucagon-like peptide 1(7-36)}. It has 100% cross reactivity to Semaglutide. The calibrators used are certified against commercially available OZEMPIC™ Injection.

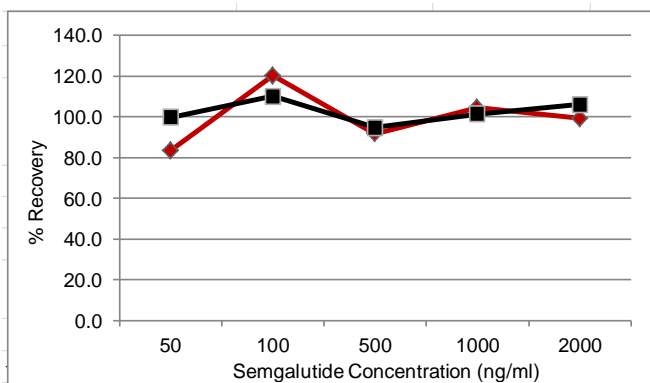

Kit Standard Concentration (ng/ml)	Ozempic Calibrator % Recovery	Kit Calibrator % Recovery
50	83.5	99.9
100	120.4	110.1
500	91.8	94.8
1000	104.7	101.5
2000	99.4	106.3

Note: Semaglutide is chemically similar to human glucagon-like peptide-1 (GLP-1), but there are some differences in their peptide chains namely, Semaglutide has two amino acid substitutions compared to human GLP-1 which is at Position 8 where Alanine is replaced by 2-aminoisobutyric acid (Aib) and at Position 34 where Lysine is replaced by arginine. Also Lysine at position 26 is acylated with a spacer and C-18 fatty diacid chain and the first six amino acids of GLP-1 are missing in Semaglutide.

The antibody used in the kit is not only specific to Semaglutide but has demonstrated cross reactivity of 100-120% against other forms of GLP-1 including exogenous GLP-1, Tirzepatide and Semaglutide salts like Semaglutide Acetate. Hence the kit has limitations when detecting Semaglutide in the presence of other GLP-1 agonists.

Linearity:

The standard graph range optimized is 0 ng/ml to 4000 ng/ml. Samples outside the assay range need be diluted using the kit Diluent provided to bring the expected results within the given assay range.

Precision:

Precision is defined as the percent coefficient of variation (%CV) i.e. standard deviation divided by the mean and multiplied by 100. Assay precision was determined by both intra (n=5 assays) and inter assay (n=5 assays) reproducibility on two pools with low (50 ng/ml), medium (1000 ng/ml) and high (4000 ng/ml) concentrations. While actual precision may vary from laboratory to laboratory and technician to technician, it is recommended that all operators achieve precision below these design goals before reporting results.

Pool	Intra Assay %CV	Inter Assay %CV
Low	<10%	<12%
Medium	<8%	<10%
High	<8%	<10%

Cross Reactivity:

The KRIBIOLISA® Semaglutide ELISA was validated for cross-reactivity with different markers and the results are as per table below.

Marker	% Cross Reactivity
Liraglutide	100-120%
endogenous GLP-1	<0.1%

Safety Precautions:

- **This kit is For Research Use Only.** Follow the working instructions carefully.
- The expiration dates stated on the kit are to be observed. The same relates to the stability stated for reagents.
- Do not use or mix reagents from different lots.
- Do not use reagents from other manufacturers.
- Avoid time shift during pipetting of reagents.
- All reagents should be kept in the original shipping container.
- Some of the reagents contain small amount of sodium azide (<0.1% w/v) as preservative. They must not be swallowed or allowed to come into contact with skin or mucosa.
- Since the kit contains potentially hazardous materials, the following precautions should be observed
 - Do not smoke, eat or drink while handling kit material
 - Always use protective gloves
 - Never pipette material by mouth
 - Wipe up spills promptly, washing the affected surface thoroughly with a decontaminant.
- In any case GLP should be applied with all general and individual regulations to the use of this kit.

**References:**

Discovery of the once-weekly glucagon-like peptide-1 (GLP-1) analogue semaglutide

J Lau, P Bloch, L Schäffer, I Pettersson... - Journal of medicinal ..., 2015 - ACS Publications

... Discovery of the Once-Weekly Glucagon-Like Peptide-1 (GLP-1) Analogue Semaglutide ... Semaglutide was selected as the optimal once weekly candidate. Semaglutide has two amino acid substitutions compared to human GLP-1 (Aib 8 , Arg 34) and is derivatized at lysine 26 ...

Lipopeptides as therapeutics: applications and in vivo quantitative analysis

J Zemenová, D Sýkora, L Maletínská, J Kuneš - Bioanalysis, 2017 - Future Science

... assays do not detect fragments of ghrelin, as observed for the single-site ELISAs that have ... ethanol

and 1.5% hydrochloric acid was reported as the sample preparation procedure preceding the ELISA. In the case of semaglutide, the other novel GLP-1 analog, the use of ELISA ...

Comparison of ELISA and HPLC-MS methods for the determination of exenatide in biological and biotechnology-based formulation matrices

AR Pinho, A Fortuna, A Falcão, AC Santos... - Journal of ..., 2019 - Elsevier

... Comparison of ELISA and HPLC-MS methods for the determination of exenatide in biological and biotechnology-based formulation matrices ... Description of main ELISA and HPLC-MS main features and comparison towards exenatide's quantification. • ...

F Azizova-Such - carlsibicky.wordpress.com

... The diagnosis of HIT is excluded if the OD of the ELISA is <0.40 and confirmed if the OD is >2.00 ... GLP-1 receptor agonists liraglutide and semaglutide significantly decrease cardiovascular death and major cardiac events; however, the cardiac benefits of this class are delayed ...

Canadian Canagliflozin Registry (CanCARE)—A Prospective, Observational, Assessment of Canagliflozin Treatment in Type 2 Diabetes Mellitus (T2DM); Six Month ... V Woo, HS Bajaj, A Bell... - Canadian ..., 2017 - canadianjournalofdiabetes.com

... After 48h of treatments, DHEA levels were measured in culture media by ELISA and corrected for protein quantification ... Semaglutide, a GLP-1 analog in development for once-weekly sub-cutaneous treatment of T2D, demonstrated superior HbA1c and body weight reductions vs ...

SCHEMATIC ASSAY PROCEDURE

1. Remove all components, 30 minutes before adding into the assay plate.

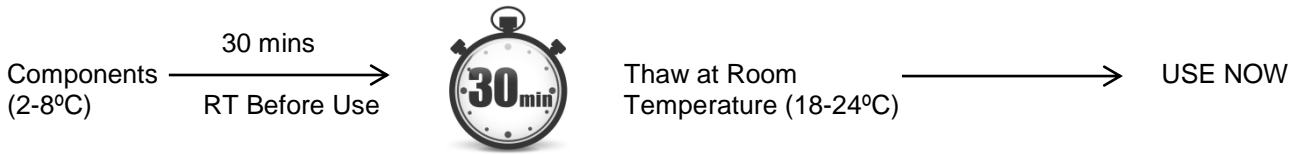

2. Avoid repeated cool-thaw of the components as there will be a loss of activity and this can affect the results.



3. Pipette **100 ul Standards / Samples** into each well.

4. Cover plate and incubate for **90 mins** at 37°C.

5. Pipette **50 ul Working Biotinylated GLP-1** into the respective wells.

6. Cover plate and incubate for **90 mins** at 37°C.

7. Aspirate and wash wells 4 times with **Wash Buffer (1X)**.

8. Pipette **100 ul Working Streptavidin:HRP Solution** into each well.

9. Cover plate and incubate for **60 mins** at 37°C.

10. Aspirate and wash wells 4 times with **Wash Buffer (1X)**.

11. Pipette **100 ul TMB Substrate** into each well.

12. Cover plate and incubate for **30 mins** at 37°C.

13. Pipette **100 ul Stop Solution** into each well.

14. Read absorbance at 450 nm with a microplate reader within **15 mins** of stopping reaction.

Typical Example of a Work List

Well #	Contents	Absorbance at 450 nm	Mean Absorbance	ng/ml Semaglutide equivalent
1A	0 ng/ml			
2A	0 ng/ml			
1B	50 ng/ml			
2B	50 ng/ml			
1C	100 ng/ml			
2C	100 ng/ml			
1D	500 ng/ml			
2D	500 ng/ml			
1E	1000 ng/ml			
2E	1000 ng/ml			
1F	2000 ng/ml			
2F	2000 ng/ml			
1G	3000 ng/ml			
2G	3000 ng/ml			
1H	4000 ng/ml			
2H	4000 ng/ml			
3A	Sample			
4A	Sample			
3B	Sample			
4B	Sample			

LIMITED WARRANTY

Krishgen Biosystems Private Limited does not warrant against damages or defects arising in shipping or handling, or out of accident or improper or abnormal use of the Products; against defects in products or components not manufactured by Krishgen Biosystems Private Limited, or against damages resulting from such non-Krishgen Biosystems Private Limited made products or components. Krishgen Biosystems Private Limited passes on to customer the warranty it received (if any) from the maker thereof of such non Krishgen made products or components. This warranty also does not apply to Products to which changes or modifications have been made or attempted by persons other than pursuant to written authorization by Krishgen Biosystems Private Limited.

THIS WARRANTY IS EXCLUSIVE. The sole and exclusive obligation of Krishgen Biosystems Private Limited shall be to repair or replace the defective Products in the manner and for the period provided above. Krishgen Biosystems Private Limited shall not have any other obligation with respect to the Products or any part thereof, whether based on contract, tort, and strict liability or otherwise. Under no circumstances, whether based on this Limited Warranty or otherwise, shall Krishgen Biosystems Private Limited be liable for incidental, special, or consequential damages.

This Limited Warranty states the entire obligation of Krishgen Biosystems Private Limited with respect to the Products. If any part of this Limited Warranty is determined to be void or illegal, the remainder shall remain in full force and effect.

Krishgen Biosystems Private Limited. 2025













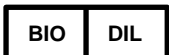

THANK YOU FOR USING KRISHGEN PRODUCT!

KRISHGEN BIOSYSTEMS PRIVATE LIMITED®, GENLISA®, DHARMAPLEX®, GENBULK®, GENLISA®, KRISHZYME®, KRISHGEN®, KRIBIOLISA®, KRISHPLEX®, TITANIUM®, QUALICHEK® are registered trademarks of KRISHGEN BIOSYSTEMS PRIVATE LIMITED. ©KRISHGEN BIOSYSTEMS PRIVATE LIMITED. ALL RIGHTS RESERVED.

KRISHGEN BIOSYSTEMS PRIVATE LIMITED | OUR REAGENTS | YOUR RESEARCH |

OZEMPIC is the registered trademark of **Novo Nordisk's**.

SYMBOLS KEY

	Anti-GLP-1 Coated Microtiter Plate (12x8 wells)
	Semaglutide Standard, Lyophilized
	GLP-1 Biotin Concentrated
	Streptavidin:HRP Conjugate Concentrated
	Biotin Diluent
	Streptavidin:HRP Diluent
	(1X) Standard Diluent
	(1X) Sample Diluent
	(20X) Wash Buffer
	TMB Substrate
	Stop Solution
	Consult Instructions for Use
	Catalog Number
	Expiration Date
	Storage Temperature