





# GENLISA™ Human Anti-SARS-CoV-2 (Covid-19) IgG Antibody to nucleoprotein Quantitative ELISA

**REF** : KBVH015-9

Ver 1.3

**RUO**

Enzyme Immunoassay for the Quantitative Estimation of IgG Antibodies to Human SARS-CoV-2 (Covid-19) in human serum and plasma, respiratory specimens and cell culture supernatant

<b>RUO</b>	<b>For Research Use Only</b>	<b>REF</b>	<b>Catalog Number</b>
	<b>Store At</b>	<b>LOT</b>	<b>Batch Code</b>
	<b>Manufactured By</b>		<b>Biological Risk</b>
	<b>Expiry Date</b>		<b>Consult Operating Instructions</b>

*For Research Use Only. Purchase does not include or carry the right to resell or transfer this product either as a stand-alone product or as a component of another product. Any use of this product other than the permitted use without the express written authorization of KRISHGEN BioSystems is strictly prohibited.*

**REF** KBVH015-9 **96 tests**

**KRISHGEN BioSystems** For US/Europe Customers: toll free +1(888)-970-0827 | tel +1(562)-568-5005  
For Asia/India Customers: tel +91(22)-49198700  
Email: sales@krishgen.com | http://www.krishgen.com

**Introduction:**

The GENLISA™ ELISA kits are used for assessing the specific biomarker in samples analytes which may be serum, plasma and cell culture supernatant as validated with the kit. The kit employs a sandwich ELISA technique which leads to a higher specificity and increased sensitivity compared to conventional competitive ELISA kits which employ only one antibody.

There is no standard reference SARS-CoV-2 antigen material available; accordingly, absolute analytical sensitivity cannot be calculated. We have used a polyclonal antibody as standard and quantified for the total protein content of the antibodies raised as 1000,000 AU/ml. The SARS-CoV-2 Antibody has not been defined or standardized worldwide. Hence this assay uses standards optimized for the linear range in the assay as AU/ml. The kit shows a typical titration curve when used in dilutions of stable below.

Standard Concentration	Standard Titre Dilution
15 AU /ml	1:66,666 titre
30 AU /ml	1:33,333 titre
60 AU /ml	1:16,667 titre
90 AU /ml	1:11,111 titre
180 AU /ml	1:5556 titre
360 AU /ml	1:2778 titre
720 AU /ml	1:1389 titre

The assay allows the quantitative determination of samples of an unknown concentration titer (immunological titer) and the calibration of the kit standards.

It is also important to note that the polyclonal antibody used as standard is interpreted as ng/ml. However, in the absence of standardization of the SARS-CoV-2 antibodies worldwide, the same are expressed as AU/ml in the kit.

**Intended Use:**

The GENLISA™ Human Anti-SARS-CoV-2 (Covid-19) IgG ELISA kit is used as an analytical tool for quantitative estimation of IgG antibodies to Human SARS-CoV-2 (Covid-19) nucleoprotein in human serum and plasma, respiratory specimens and cell culture supernatant.

**Principle:**

The method employs sandwich ELISA technique. Human SARS-CoV-2 nucleoprotein is pre-coated onto microwells. Samples and standards are pipetted into microwells and IgG Antibodies to human SARS-CoV-2 (Covid-19) present in the sample are bound by the protein antigen. After incubation the wells are washed and followed by HRP-conjugated Detection IgG Antibody is pipetted and incubated to form a complex. After washing microwells in order to remove any non-specific binding, the substrate solution (TMB) is added to microwells and color develops proportionally to the amount of IgG Anti-Human SARS-CoV-2 (Covid-19) in the sample. Color development is then stopped by addition of stop solution. Absorbance is measured at 450 nm.

**Materials Provided:**

1. Recombinant SARS-CoV-2 (Covid-19) nucleoprotein Coated Microtiter Plate (12 x 8 wells) - 1 no
2. Anti-Human SARS-CoV-2 (Covid-19) nucleoprotein Standard (conc., lyophilized 1000 AU/ml) - 2 vials
3. Anti Human IgG:HRP Conjugate – 12 ml
4. Standard Diluent - 10 ml
5. (5X) Assay Diluent - 50 ml
6. (20X) Wash Buffer - 25 ml
7. TMB Substrate - 12 ml
8. Stop Solution - 12 ml

**Materials to be provided by the End-User:**

1. Microtiter Plate Reader able to measure absorbance at 450 nm.
2. Adjustable pipettes and multichannel pipettor to measure volumes ranging from 25 ul to 1000 ul
3. Deionized (DI) water
4. Wash bottle or automated microplate washer
5. Graph paper or software for data analysis
6. Timer
7. Absorbent Paper

**Handling/Storage:**

1. Store main kit components at 2-8°C.
2. Before using, bring all components to room temperature (18-25°C). Upon assay completion return all components to appropriate storage conditions.
3. The Substrate is light-sensitive and should be protected from direct sunlight or UV sources.

**Health Hazard Warnings:**

1. Reagents that contain preservatives may be harmful if ingested, inhaled or absorbed through the skin.

**Sample Preparation and Storage:**

Specimens should be clear and non-hemolyzed. Samples should be run at a number of dilutions to ensure accurate quantitation.

Blood is taken by venipuncture. Serum is separated after clotting by centrifugation. Plasma can be used, too. Lipaemic, hemolytic or contaminated samples should not be run. Repeated freezing and thawing should be avoided. If samples are to be used for several assays, initially aliquot samples and keep at -20°C.

Samples should be diluted 1:5000 (v/v) for optimal recovery, (for example 1 ul sample + 4999 ul 1x Assay diluent) prior to assay. In cases where matrix interferences is under or over observed, the samples may be diluted with Assay Diluent accordingly.

The samples may be kept at 2 - 8°C for up to three days. For long-term storage please store at -20°C.

**Note:** *Grossly hemolyzed samples are not suitable for use in this assay*

Cell Culture Supernates - Remove particulates by centrifugation and assay immediately or aliquot and store samples at -20°C or lower temperature. Avoid repeated freeze-thaw cycles. If the use of original supernate sample or low dilution (<5 fold) are necessary due to the expected low concentration of antigen supernates need be adjust to neutral pH condition before assay.

Should you desire to inactivate the virus, use a (5X) Lysis Buffer (optional, not provided). Add 1/5 volume of (5X) Lysis Buffer to sample (i.e. add 50 ul (5X) Lysis Buffer to 200 ul sample). Vortex well.

Note:

The sample should be diluted to within the working range of the assay in 1X Assay Diluent. The exact dilution must be determined based on the concentration of specific target in individual samples.

Respiratory Sample - Centrifuge samples for 20 minutes at 10000 x g at 2-8°C. Collect supernatant and carry out the assay immediately.

**Reagent Preparation (all reagents should be diluted immediately prior to use):**

1. Label any aliquots made with the kit Lot No and Expiration date and store it at appropriate conditions mentioned.
2. Bring all reagents to Room temperature before use.

3. To make **Assay Diluent (1X)**; dilute **50 ml of 5X Assay Diluent in 200 ml of DI water**.
4. To make **Wash Buffer (1X)**; dilute **25 ml of 20X Wash Buffer in 475 ml of DI water**.
5. **Standards Preparation**: Reconstitute the concentrated Standard lyophilized vial with 1 ml of Standard Diluent to obtain a concentration of 1000 AU/ml. Keep the vial for 15 mins with gentle agitation before making further dilutions. Dilute 360 ul of original **Standard (1000 AU/ml)** with 140 ul of Standard Diluent to generate a **720 AU/ml Standard Solution**. Prepare further **Standards** by serially diluting the Standard Solution as per the below table. Use the Standard Diluent as the Zero Standard (Standard No.0).

Standard Concentration	Standard Vial	Dilution Particulars
1000 AU/ml	Original Standard	Original Standard provided in the Kit
720 AU/ml	Standard No.7	360 ul Original Standard (1000 AU/ml) + 140 ul Standard Diluent
360 AU/ml	Standard No.6	250 ul Standard No.7 + 250 ul Standard Diluent
180 AU/ml	Standard No.5	250 ul Standard No.6 + 250 ul Standard Diluent
90 AU/ml	Standard No.4	250 ul Standard No.5 + 250 ul Standard Diluent
60 AU/ml	Standard No.3	333.4 ul Standard No.4 + 166.6 ul Standard Diluent
30 AU/ml	Standard No.2	250 ul Standard No.3 + 250 ul Standard Diluent
15 AU/ml	Standard No.1	250 ul Standard No.2 + 250 ul Standard Diluent
0 AU/ml	Standard No. 0	Only Standard Diluent

Use the Standards as soon as possible upon reconstitution. Discard balance standards after use.

### Procedural Notes:

1. In order to achieve good assay reproducibility and sensitivity, proper washing of the plates to remove excess un-reacted reagents is essential.
2. High Dose Hook Effect may be observed in samples with very high concentrations of Anti-Human SARS-CoV-2 (Covid-19) IgG. High Dose Hook Effect is due to excess of antibody for very high concentrations of Anti-Human SARS-CoV-2 (Covid-19) IgG present in the sample.
3. Avoid assay of Samples containing sodium azide ( $\text{NaN}_3$ ), as it could destroy the HRP activity resulting in under-estimation of the amount of Anti-Human SARS-CoV-2 (Covid-19).
4. It is recommended that the Standards and Samples be assayed in duplicates.
5. Maintain a repetitive timing sequence from well to well for all the steps to ensure that the incubation timings are same for each well.
6. If the Substrate has a distinct blue color prior to use it may have been contaminated and use of such substrate can lead to compromisation of the sensitivity of the assay.
7. The plates should be read within 30 minutes after adding the Stop Solution.
8. Make a work list in order to identify the location of Standards and Samples.

### Assay Procedure:

1. Pipette **100 ul of prepared Standards and Samples** to the respective wells.
2. Seal the plate and incubate for 1 hour at Room Temperature (18-25°C).
3. Aspirate and wash plate 4 times with **Wash Buffer (1X)** and blot residual buffer by firmly tapping plate upside down on absorbent paper. Wipe of any liquid from the bottom outside of the microtiter wells as any residue can interfere in the reading step. All the washes should be performed similarly.
4. Add **100 ul of Anti-Human IgG: HRP Conjugate** to each well.
5. Seal the plate and incubate for 1 hour at Room Temperature (18-25°C).

6. Wash plate 4 times with **Wash Buffer (1X)** as in step 2.
7. Pipette **100 ul** of **TMB Substrate solution**.
8. Incubate in the dark for 15 minutes at Room Temperature.
9. Stop reaction by adding **100 ul** of **Stop Solution** to each well.
10. Read absorbance at 450 nm within 30 minutes of stopping reaction.

### Calculation of Results:

Determine the Mean Absorbance for each set of duplicate Standards and Samples. Using standard graph paper, plot the average value (absorbance 450nm) of each standard on the Y-axis versus the corresponding concentration of the standards on the X-axis. Draw the best fit curve through the standard points.

To determine the unknown Human Anti SARS-CoV-2 nucleoprotein IgG concentrations, find the unknown's Mean Absorbance value on the Y-axis and draw a horizontal line to the standard curve. At the point of intersection, draw a vertical line to the X-axis and read the concentration. If samples were diluted, multiply by the appropriate dilution factor.

Software which is able to generate a polynomial regression (2<sup>nd</sup> order) or a cubic spline curve-fit is best recommended for automated results.

### Note:

It is recommended to repeat the assay at a different dilution factor in the following cases:

- If the sample absorbance value is below the first standard.
- If the absorbance value is equivalent or higher than the 720 AU/ml standard.

### Typical Data

Standard Conc (AU/ml)	Abs 1	Abs 2	Mean Abs	Interpolated Concentration	% Interpolated Concentration against Actual Concentration
0	0.367	0.349	0.358	2.9	--
15	0.419	0.377	0.398	12.2	81.7
30	0.506	0.488	0.497	31.4	104.5
60	0.661	0.637	0.649	60.2	100.4
90	0.740	0.812	0.776	86.9	96.5
180	1.111	1.149	1.130	190.3	105.7
360	1.406	1.381	1.394	338.2	93.9
720	1.642	1.670	1.656	750.2	104.2

### Typical Graph

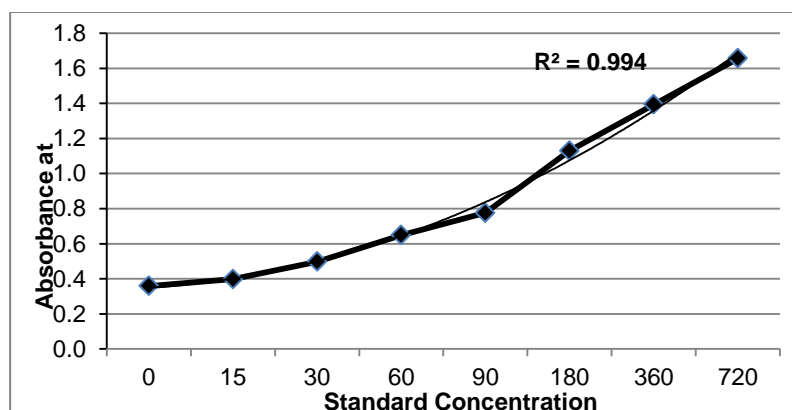

\*note: AU/ml = ng/ml of recombinant protein used in this kit

**Quality Control:**

It is recommended that for each laboratory assay appropriate quality control samples in each run to be used to ensure that all reagents and procedures are correct.

**Performance Characteristics of the Kit:**

**Sensitivity:**

**Limit Of Detection:** There is no standard reference SARS-CoV-2 antigen material available; accordingly, absolute analytical sensitivity cannot be calculated. Based on the kit working standards the LOD is 10 AU/ml

**Specificity:**

Reactivity/Inclusivity

Mutations in the SARS-CoV-2 genome have been identified as the virus has spread, but no serologically unique strains have been described relative to the originally isolated virus (this research is limited at present).

Cross-reactivity of non-SARS-CoV-2 specific antibodies against SARS-CoV-2 nucleocapsid proteins in Anti-SARS-CoV-2 ELISA KBVH015-9 was examined using sera with known antibodies against confirmed past infections.

N	Antibody Positive Sera	Anti-SARS-CoV-2 ELISA #KBVH015-9
1	Beta Corona HKU1*	Negative
4	VCV	Negative
5	HCV	Negative
4	HAV	Negative
3	HBV	Negative
4	EBV	Negative
5	CMV	Negative
5	HSV	Negative

\*The patient was tested PCR positive for Beta Corona HKU1 and PCR negative for SARS-CoV-2. Four weeks after PCR testing a serum sample was drawn from the patient and found to be negative in the Anti-SARS-CoV-2 ELISA.

**Traceability:**

There are no reference standards for SARS-Cov-2 Antibody. The results are reported in AU/ml and the method has been standardized in our laboratory at KRISHGEN BIOSYSTEMS.

**Linearity:**

Standards provided in the kit were used for measuring the linearity range of IgG Antibodies to SARS-CoV-2 present in matrix. The Standards / Calibrator Range is 0 - 720 AU/ml.

**Precision:**

Precision is defined as the percent coefficient of variation (%CV) i.e. standard deviation divided by the mean and multiplied by 100. Assay precision was determined by both intra (n=5 assays) and inter assay (n=5 assays) reproducibility on two pools with low (15 AU/ml), medium (180 AU/ml) and high (720 AU/ml) concentrations. While actual precision may vary from laboratory to laboratory and technician to technician, it is recommended that all operators achieve precision below these design goals before reporting results.

Pool	Intra Assay %CV	Inter Assay %CV
Low	<10%	<12%
Medium	<8%	<8%
High	<8%	<8%

**Recovery:**

Human sera and plasma were measured with two replicates and two runs (n = 5). The human sera and plasma were pooled patient and single donor spiked samples. Samples were measured using one lot of reagent. All data met our acceptance criteria for % CV and 95% (CI) Confidence Intervals for % CV.

Matrix	Recovery Range %
Serum (n=5)	87 - 112
Plasma EDTA (n=5)	85 - 114
Plasma Heparin (n=5)	86 - 114

Note: Serum and Plasma were diluted using Assay Diluent provided with the kit

**Assay Comparison:**

To demonstrate the identity of the Anti-SARS-CoV-2 ELISA and a commercially available COVID-19 IgG / IgM Rapid Test, 9 serum samples were measured using both assays. In comparison, the results of the IgG tests show an increased sensitivity of the anti-SARS-CoV-2 ELISA.

Sample No.	Anti-SARS-CoV-2 ELISA	COVID-19 IgG / IgM Rapid Test
1	positive +	negative
2	positive +	positive
3	positive +	negative
4	negative -	negative
5	borderline +	slightly positive
6	positive +++	positive
7	negative -	negative
8	negative -	negative
9	positive ++	positive

**Longitudinal Reponse of Antibodies to SARS-CoV-2.**

**Antibodies response to the Nucleocapsid Proteins and the Spike Proteins of IgG and IgM:**

figure a and b

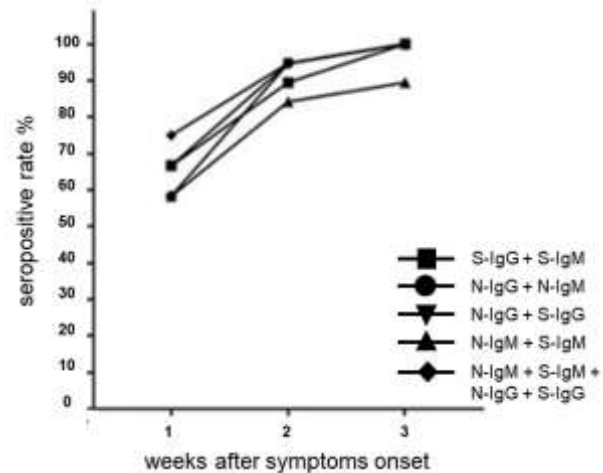
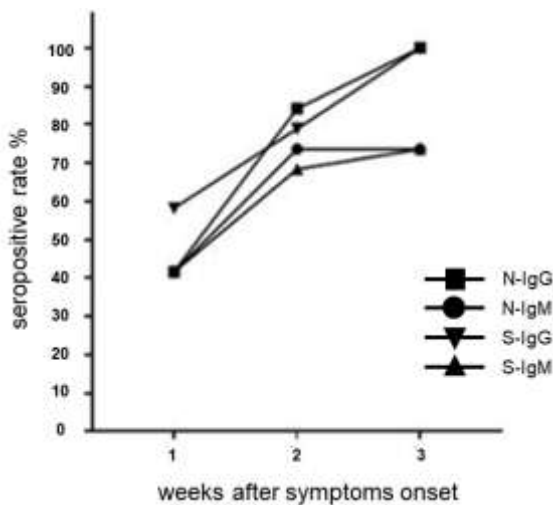

Weeks	N-IgM	N-IgG	S-IgM	S-IgG	N-IgM + N-IgG	S-IgM + S-IgG	N-IgM + S-IgM	N-IgG + S-IgG	N-IgM+ S-IgM+ N-IgG+ S-IgG
1	41.7	41.7	41.7	58.3	58.3	66.7	58.3	66.7	75
2	73.7	84.2	68.4	78.9	94.7	89.5	84.2	94.7	94.7
3	73.7	100	73.7	100	100	100	89.5	100	100

**Reference:**

**EMERGING MICROBES AND INFECTIONS JOURNAL**

Accepted author version posted online: 01 May 2020

**Kinetics of SARS-CoV-2 specific IgM and IgG responses in COVID-19 patients**

Baoqing Sun, Ying Feng, Xiaoneng Mo, Peiyan Zheng, Qian Wang, Pingchao Li, Ping Peng, Xiaoqing Liu, Zhilong Chen, Huimin Huang, Fan Zhang, Wenting Luo, Xuefeng Niu, Peiyu Hu, Longyu Wang, Hui Peng, Zhifeng Huang, Liqiang Feng, Feng Li, Fuchun Zhang, Fang Li, Nanshan Zhong & Ling Chen

<https://doi.org/10.1080/22221751.2020.1762515>

**Safety Precautions:**

- **This kit is For Research Use Only.** Follow the working instructions carefully.
- The expiration dates stated on the kit are to be observed. The same relates to the stability stated for reagents
- Do not use or mix reagents from different lots.
- Do not use reagents from other manufacturers.
- Avoid time shift during pipetting of reagents.
- All reagents should be kept in the original shipping container.
- Some of the reagents contain small amount of sodium azide (< 0.1 % w/w) as preservative. They must not be swallowed or allowed to come into contact with skin or mucosa.
- Source materials maybe derived from human body fluids or organs used in the preparation of this kit were tested and found negative for HBsAg and HIV as well as for HCV antibodies. However, no known test guarantees the absence of such viral agents. Therefore, handle all components and all patient samples as if potentially hazardous.
- Since the kit contains potentially hazardous materials, the following precautions should be observed
  - Do not smoke, eat or drink while handling kit material
  - Always use protective gloves
  - Never pipette material by mouth
  - Wipe up spills promptly, washing the affected surface thoroughly with a decontaminant.
- In any case GLP should be applied with all general and individual regulations to the use of this kit.

**References:**

Structure, function, and antigenicity of the SARS-CoV-2 nucleocapsid glycoprotein  
AC Walls, YJ Park, MA Tortorici, A Wall, AT McGuire...  
- Cell, 2020 - Elsevier

Preliminary identification of potential vaccine targets for the COVID-19 coronavirus (SARS-CoV-2) based on SARS-CoV immunological studies  
SF Ahmed, AA Quadeer, MR McKay  
- Viruses, 2020 - mdpi.com

Interaction between heptad repeat 1 and 2 regions in nucleocapsid protein of SARS-associated coronavirus: implications for virus fusogenic mechanism and identification of ...  
S Liu, G Xiao, Y Chen, Y He, J Niu, CR Escalante...  
- The Lancet, 2004 - Elsevier

Temporal profiles of viral load in posterior oropharyngeal saliva samples and serum antibody responses during infection by SARS-CoV-2: an observational cohort ...  
KKW To, OTY Tsang, WS Leung, AR Tam...  
- The Lancet Infectious ..., 2020 - Elsevier

Modulation of the unfolded protein response by the severe acute respiratory syndrome coronavirus nucleocapsid protein  
CP Chan, KL Siu, KT Chin, KY Yuen, B Zheng...  
- Journal of ..., 2006 - Am Soc Microbiol

Functional assessment of cell entry and receptor usage for SARS-CoV-2 and other lineage B betacoronaviruses  
M Letko, A Marzi, V Munster  
- Nature microbiology, 2020 - nature.com

**SCHEMATIC ASSAY PROCEDURE**



1. Remove all components, 30 minutes before adding into the assay plate.



2. Avoid repeated cool-thaw of the components as there will be a loss of activity and this can affect the results.

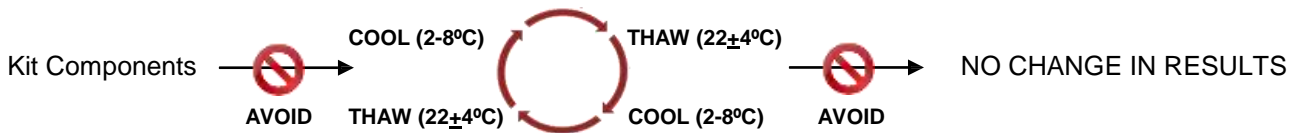

3.  Pipette **100 ul Standards and diluted Samples** into the respective wells.

4.  Cover plate and **incubate** for  at Room Temperature.

5.  Aspirate and wash wells 4 times with **Wash Buffer (1X)**.

6.  Pipette **100 ul Anti-Human IgG:HRP Conjugate** into each well.

7.  Cover plate and **incubate** for  at Room Temperature.

8.  Aspirate and wash wells 4 times with **Wash Buffer (1X)**.

9.  Pipette **100 ul TMB Substrate** into each well.

10.  Cover plate and **incubate** for  at Room Temperature.

11.  Pipette **100 ul Stop Solution** into each well.

12. Read absorbance at 450nm with a  microplate reader within  of stopping reaction.

**Typical Example of a Work List**

Well #	Contents	Absorbance at 450nm	Mean Absorbance	Results
1A 2A	0 Standard 0 Standard			
1B 2B	15 AU/ml 15 AU/ml			
1C 2C	30 AU/ml 30 AU/ml			
1D 2D	60 AU/ml 60 AU/ml			
1E 2E	90 AU/ml 90 AU/ml			
1F 2F	180 AU/ml 180 AU/ml			
1G 2G	360 AU/ml 360 AU/ml			
1H 2H	720 AU/ml 720 AU/ml			
3A 4A	<i>Sample</i>			
3B 4B	<i>Sample</i>			

**LIMITED WARRANTY**

Krishgen Biosystems does not warrant against damages or defects arising in shipping or handling, or out of accident or improper or abnormal use of the Products; against defects in products or components not manufactured by Krishgen Biosystems, or against damages resulting from such non-Krishgen Biosystems made products or components. Krishgen Biosystems passes on to customer the warranty it received (if any) from the maker thereof of such non Krishgen made products or components.

This warranty also does not apply to Products to which changes or modifications have been made or attempted by persons other than pursuant to written authorization by Krishgen Biosystems.











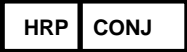

THIS WARRANTY IS EXCLUSIVE. The sole and exclusive obligation of Krishgen Biosystems shall be to repair or replace the defective Products in the manner and for the period provided above. Krishgen Biosystems shall not have any other obligation with respect to the Products or any part thereof, whether based on contract, tort, and strict liability or otherwise. Under no circumstances, whether based on this Limited Warranty or otherwise, shall Krishgen Biosystems be liable for incidental, special, or consequential damages.

This Limited Warranty states the entire obligation of Krishgen Biosystems with respect to the Products. If any part of this Limited Warranty is determined to be void or illegal, the remainder shall remain in full force and effect.

Krishgen Biosystems. 2021

**THANK YOU FOR USING KRISHGEN PRODUCT!**

**SYMBOLS KEY**

	Recombinant SARS-CoV-2 (Covid-19) nucleocapsid protein Coated Microtiter Plate
	Anti-Human SARS-CoV-2 (Covid-19) Standards
	Anti Human IgG:HRP Conjugate
	Standard Diluent
	(5X) Assay Diluent
	(20X) Wash Buffer
	TMB Substrate
	Stop Solution
	Consult Instructions for Use
	Catalogue Number
	Expiration Date
	Storage Temperature